



ATV Glue On Heated Grips Installation Instructions

For the following kits: 210015 High/Low Hand Warming for ATVs

WARNING: NOT FOR USE ON MOTORCYCLES (could deform throttle, causing it to not turn)

APPLICATION

ATVs with 7/8" bar and thumb throttle; Polaris, Honda, Arctic Cat, Yamaha, Bombardier, Kawasaki, and Suzuki

SPECIFICATIONS

Wattage: 19 watts High (38 watts total) at 13.5 volts
Resistance: Between red (Ground) and white (High) is 9.6+/- 2 ohms. Between red and blue (Low) is 19.2 +/- 3 ohms.

PARTS LIST



No.	Description	Qty
(1)	Heated grips	2
(2)	Rocker Switch	1
(3)	Connecting lead w/conn.	1
(4)	Piggyback connectors	2
(5)	Slip-on connectors	2
(6)	Ring connectors	2
(7)	In-line tap connector	1
(8)	Tie wraps	6
	Adhesive (parts A and B)	1 each

TOOLS/SUPPLIES FOR INSTALLATION

Drill with 13/16" bit

Pliers

Crimping tool (optional)

4-amp fuse (optional)

Contact cleaner or alcohol

Electrical tape (optional)

Pencil

Clean cloth

INSTALLATION ISSUES

- Heater designed for operation on a handlebar in a voltage-controlled circuit, do not energize before installation or heater will be damaged

- 40 watts or 3 Amps required (may preclude use on some older ATVs)

INSTALLATION INSTRUCTIONS

1. Disconnect Positive terminal from battery.
2. Remove existing grips (Removal of the existing grip may require blowing compressed air in the end (between the grip and the bar), rolling back the grip, or cutting it off. If your ATV has a bolt retainer, re-install it after the new heated grips are installed.). Clean handlebar with contact cleaner or alcohol to remove any residue and dry with clean cloth (not paper towels as they may contain silicones).

Adhesive: Completely dispense both tubes of adhesive and thoroughly mix the components to achieve a consistent color. Once mixed, the adhesive has a 25-min. handling time and cures to 90% bonding strength in 24 hours. Apply a thin coat of adhesive to the inside of the heated grip and to outside of the handle bar (within the last 4 inches of the bar). Spread adhesive by rolling a pencil or similar object around the bar and on the inside of the heated grip. Slide onto bar and twist back and forth two to three times to ensure proper coverage of adhesive (wipe off excess). Although adhesive will cure in lower temperatures, the recommended temperature is above 50 deg. F. Test for adhesive cure by examining any exposed adhesive, which is hard when cured (do not test by twisting grip during first 24 hours).

3. Left (non-throttle side) heated grip: Position wire leads at 9 o'clock position as viewed from end of bar.
4. Right (throttle side) heated grip: Position wire leads at 3 o'clock position as viewed from end of bar.
5. Choose a location for the switch that is convenient and has sufficient rear clearance for electrical connections. Switch should be within 18" of a voltage-controlled wire (wire in the lighting circuit). Drill a 13/16" hole in the selected location.
6. Route wires from each heated grip along the handlebar to switch area and out the switch hole. Routed wires should be secured with supplied tie wraps, electrical tape, or both. Cut off wires 4" to 6" beyond switch hole. Attach included wire terminals to appropriate wires.
7. Locate a voltage controlled power wire (such as one leading to a headlight, taillight, or dash light). Using the red tap connector, place this power wire into the continuous channel. Insert the yellow/red wire (do not strip insulation) into the adjacent channel. Using pliers, press the metal contact flush with top of connector. Close the hinged cover until latched. See Figure 1 for connection to switch.
8. Connect wires to switch per Fig. 1 and press switch into switch hole. **The circuitry inside the switch is transposed.**

Note: For added protection, install a 4- or 5-amp fuse (not included) between the tap connector and the switch.

9. Reconnect Positive battery terminal. Confirm no battery drain when key in Off position.

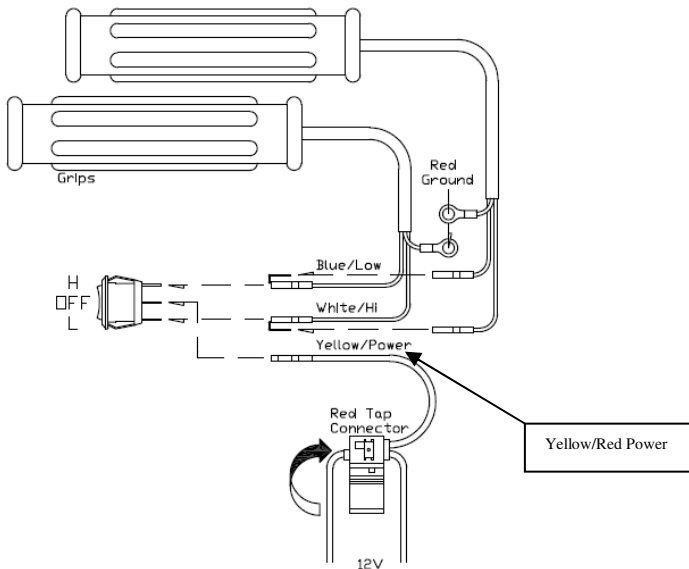

Figure 1. Connector guide & switch connections.

INSTALLATION WITH THUMB WARMER (single switch)

Though a separate switch for hand and thumb warmers offers flexibility, the following describes a single switch installation (one switch controls both hand and thumb warmers simultaneously). Combining hand and thumb warmer leads into a single connector will reduce space and connector requirements.

Installation with Thumb Warmer Kits 210008, 09, 12, and 13 (Polaris/Honda, for example) (Figure 2)

- 1) Connect the Blue Wire on the thumb warmer to the Blue Wire from the hand warmer (solder or twist tie).
- 2) Connect the White Wire on the thumb warmer to the White Wire from the hand warmer (solder or twist tie).
- 3) Connect the Red wire to a good ground.

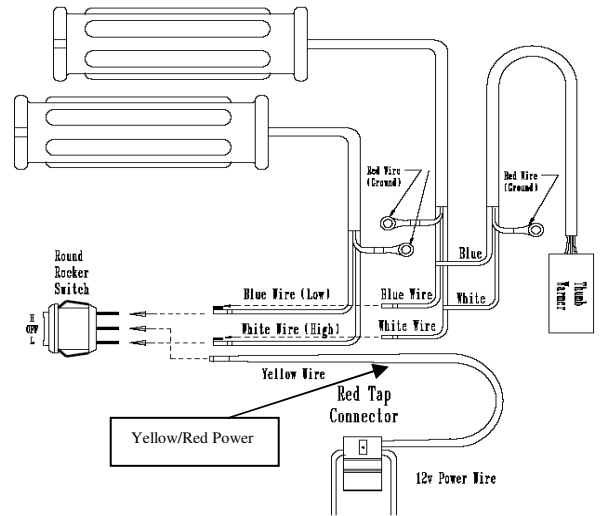

Figure 2. Hand Warmer w/210008 Type Thumb Warmer

Installation with Thumb Warmer Kits 210010 and 11 (Arctic Cat/Bombardier/Suzuki) (Figure 3)

- 1) Connect black wire from thumb warmer to Low (top) terminal of the switch. (Solder or twist/crimp hand warmer (blue wire) and thumb warmer (black) wires together).
- 2) Connect the red wire from thumb warmer to the High (bottom) terminal of the switch (along with white wire from hand warmer). Connect remaining (brown) thumb warmer wire to Ground.

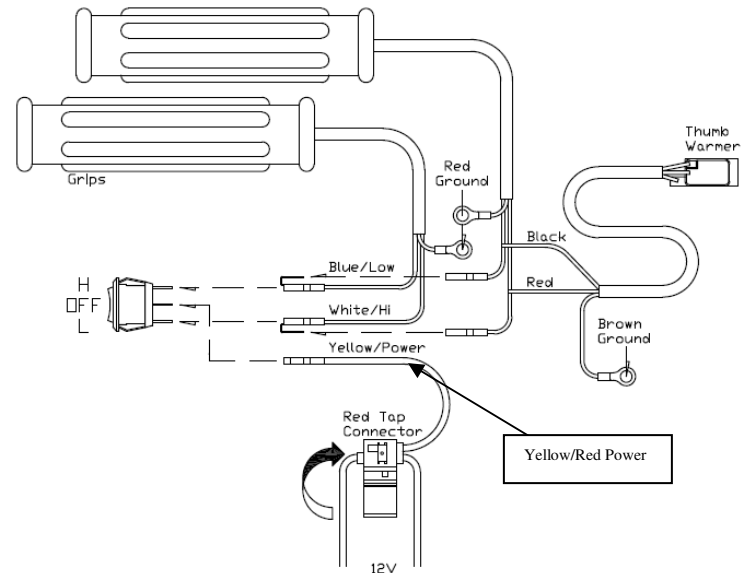

Figure 3. Hand Warmer w/210010 Type Thumb Warmer.

Warning: Ensure free movement of throttle and handlebar from side to side (and any other control in handlebar area).

Caution: Older ATVs may not provide sufficient wattage to operate headlight and heated grips at the same time without dimming the headlight. Turn heated grips off during low light conditions if visibility is poor/limited.



124 Osborne Road NE
Fridley, MN 55432
(763) 571-9193

Web site: www.symtec-inc.com
email: sales@symtec-inc.com

GlueOnGrip_1
04/26/11