

Winter Pak PLUS ATV 2/4 Zone Heated Grips, Thumb Warmer and Controller 210040, 210048, 0631-0014

**DO NO USE ON SNOWMOBILES OR OTHER DEVICES WITHOUT A
REGULATED DC POWER SUPPLY. IT WILL NOT WORK!**

Components: The Winter Pak Plus from Symtec, Inc. includes a set of Hand Warmer Grips, an easy to apply Thumb Warmer, a four function 6 5 level Temperature Controller, the accessories to install these components, and Installation and Operating Instructions to assist vehicle owners. Some kits also contain a DC plug to use in the 4-zone feature for connecting accessory heating devices.

Installation Instructions:

Mounting Hand warmer Grips and Thumb Warmer.

1. Disconnect positive terminal from battery.
2. Remove existing by either blowing compressed air in the end, rolling back the grip, or cutting it off. If your ATV has a bolt and retainer, re-install it after the new heated grips are installed. Clean handlebar with contact cleaner or alcohol to remove any residue and dry with clean cloth (not paper towels as they may contain silicones).

Adhesive: Completely dispense and thoroughly mix both tubes of adhesive until a consistent color is achieved. Once mixed, the adhesive has a 25-min. handling time and cures to 90% bonding strength in 24 hours. Apply a thin coat of adhesive to the inside of the heated grip and to outside of the handle bar (within the last 4 inches of the bar). Spread adhesive by rolling a pencil or similar object around the bar and on the inside of the heated grip. Slide onto bar and twist a couple of times to ensure proper coverage of adhesive (wipe off excess). Though adhesive will cure in lower temperatures, the recommended temperature is above 50 deg. F. Test for adhesive cure by examining any exposed adhesive, which is hard when cured (do not twist grip during first 24 hours).

3. Once grips are installed, position wire leads to desired location.
4. Peel the release paper from the Thumb Warmer and adhere it to the thumb side of the throttle.
5. Slide the piece of heat shrink tubing over the Thumb Warmer and throttle, use a heat gun or other heat source to shrink the tubing with out burning it.
6. Use a cable tie on the throttle to secure the wires and provide a strain relief.
7. Push the throttle full throttle, route wire using cable ties, leave relief in the wire so the throttle in the full open position does not strain the wire.

Mounting the Temperature Controller.

Determine if there is room to mount the Temperature Controller on the handlebar. If there is a good location follow the Option A instructions and Figure 1 for the handlebar mounting. If the controller would be more accessible mounted on a panel or other surface, follow Option B mounting instructions and refer to Figure 2.

Option A: Figure 1

1. If the handlebar is the smaller 7/8" diameter type insert the rubber spacer (item 8) and slide the handlebar mount (item 7) over the bar. For larger diameter bars, place the piece of electrical tape around the bar at the chosen mounting location. Slide the handlebar mount (item 7) over the taped bar. Insert a nut (item 4) into the side of the mount with the 6 sided recess. Install a screw (item 5) and tighten lightly.
2. Attach the Pivot (item 6) to the handlebar mount (item 7) with the shorter screw (item 2) and nut (item 4) inserted in the mount. Install a lock washer

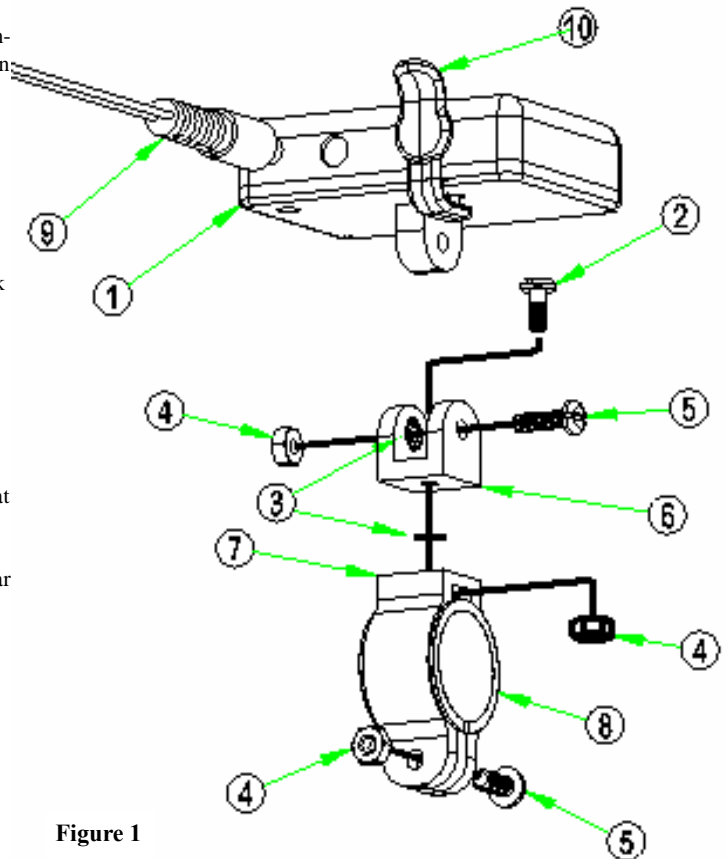

Figure 1

3. Place the tab on the bottom of the Temperature Controller (item 1) in the slot of the Pivot (item 6) and insert the screw (item 5). At this point rotate the handlebar mount (item 7), the Pivot, and the Temperature Controller to a location that provides the best view of the Controller to the driver.
4. Tighten the screw (item 5) on the bottom of the handlebar mount to secure it to the handlebar.
5. Without moving the Pivot, (item 6) remove the screw (item 5) holding the Controller to the Pivot and set the Controller aside.
6. Securely tighten the screw (item 2) that attaches the Pivot to the handlebar mount fixing the Pivot angle.
7. Attach the Temperature Controller to the Pivot with the screw (item 5) and nut placed in the 6 sided recess of the Pivot. Insert a lock washer (item 3) in the slot of the Pivot along with the tab from the bottom of the Temperature Controller as the screw is inserted. The lock washer will keep the Controller from moving when the screw is tightened.
8. Rotate the Controller to the correct angle for viewing and tighten the screw.

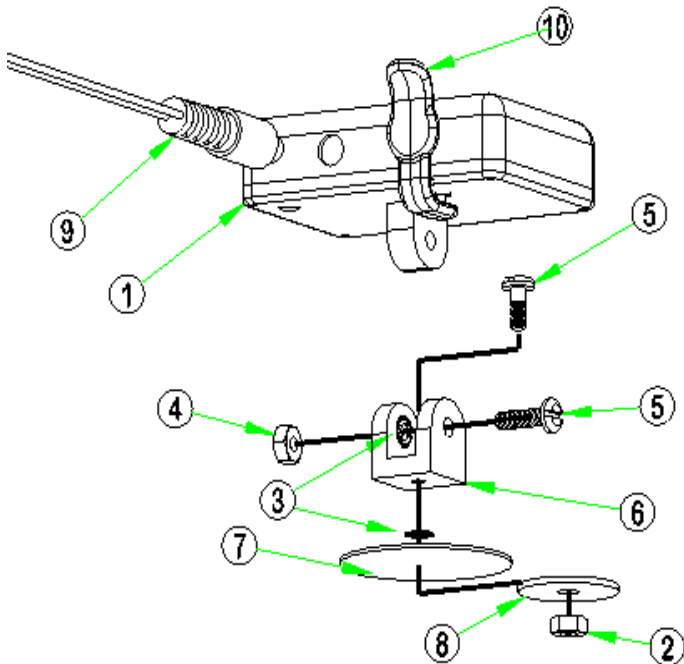

Figure 2

- Using the cable ties, route the wires from the Controller, Grips, and Thumb Warmer to a common connection point.

Option B: Figure 2

- Attach the Temperature Controller (item 1) to the Pivot (item 6) with screw (item 5) and nut (item 4).
- Choose a point on a panel or surface where the Controller will be mounted. The location should be chosen where a hole can be drilled in the panel and have access to install a washer and nut on the bottom side. Adjust the angle of the Controller for the best view for the driver and mark the angle that the Pivot will be installed.
- Drill a 5/32" hole in the panel where the pivot should be mounted.
(Be sure that you do not drill into the gas tank)
- Separate the Controller and install the Pivot, at the angle marker previously, with the screw (item 5, removed from the bottom of the handlebar mount), fender washer (item 10), and locking nut (item 9). Place the locking washer (item 3) between the Pivot and the panel to keep it from rotating.
- Attach the Controller (item 1) to the Pivot with the screw (item 5) and nut placed in the 6 sided recess of the Pivot. Insert a lock washer (item 3) in the slot of the Pivot along with the tab from the bottom of the Controller as the screw is inserted. The locking washer will keep the Controller from moving after the screw is tightened.
- Rotate the Controller to the best angle for viewing and tighten the screw.
- Using the cable ties, route the wires from the Controller, Grips, and Thumb Warmer to a common connection point.

Electrical Connections: Figure 3

- Insert the pin connectors from the left grip into the center holes of the 6 pin connector. Assure they are secure and cannot come out.
- Connect the 6 pin Female Connector from the Grips and Thumb Warmer to the 6 pin Male Connector from the Temperature controller.
- Connect the Red wire to 12V. Locate a voltage controlled power wire. We strongly recommend using the accessory plug or the hot wire to the headlight switch. Using the red tap connector, place this power wire into the continuous channel and insert the red wire into (do not strip) into adjacent channel. Using pliers, press the metal contact flush with top of connector. Close the hinged cover until latched.
- Connect the Black wire to a ground. For Ground connection use a frame component or a Ground wire, not a rubber isolated component such as a handlebar or a steering assembly. Use the red tap connector described in item 3 above or the ring terminal.

Operating Instructions: After the Winter package is installed on your vehicle you will be able to select and adjust the heat level of the Hand Warmers and Thumb Warmer. There are switches under the red circle marker "SELECT" and "POWER SET" on the Temperature Controller and these will be pressed to make the adjustments.

- When the ignition is turned on the LED above the word "GRIPS" will be on.
- With the "POWER SET" pad select the heat level for the Hand Warmer Grips. Each time the pad is pressed another LED will light indicating a higher heat level. Pressing the pad 5 times will provide the highest level of heat. When the pad is pressed again the heat will be off and the heat level selection can start again.
- Press the "SELECT" pad and the LED above the word "GRIPS" will go off and the LED above the word "THUMB" will light indicating the heat level of the Thumb Warmer can be set.
- Press the "POWER SET" pad to select the heat level for the Thumb Warmer. Setting the heat level for the Thumb Warmer will not affect the heat level set previously for the Hand Warmers.
- Pressing the "SELECT" pad will switch between the GRIP and THUMB allowing the heat level of each to be adjusted.
- The Temperature Controller will shut off automatically after 2 hours if no adjustments are made. To reactivate the Temperature Controller press the "SELECT" pad and reset the desired heat levels.
- Press both the "SELECT" and the "POWER SET" pads at the same time to change the light level of LED for night or day operation.

4 Zone Controller

- The two plugs (10) keep dirt out of the Auxiliary 1 and 2 plugs. Keep these plugged when not in use. Each of these outputs supplies up to 60 watts of power for use with a heated seat, heated vest, foot warmers or any other 12 volt apparatus.
- ONE DC plug (9) is supplied with the kit which you can use to connect to a heated vest, seat heater or similar device.
- Both controllers have memory functions such that if the power is shut off and then restored, the previous heat settings will be restored.

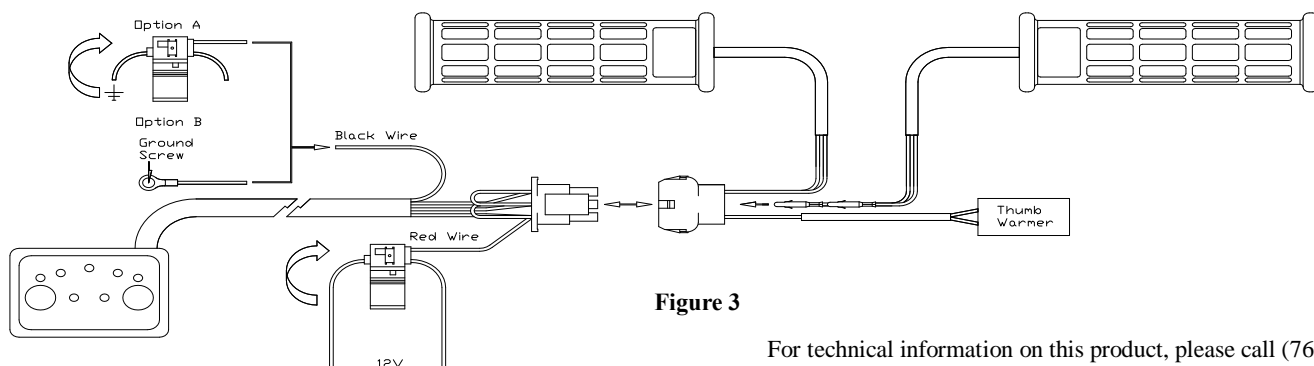

Figure 3